

## Device image(s)



## Device identification

- Device name: **Shelly Dimmer Gen3**
- Device model: **S3DM-0A101WWL**
- Device SSID: **ShellyDimmerG3-XXXXXXXXXXXX**
- Device Bluetooth ID: **0x1073**

## Short description

Shelly Dimmer Gen3 (the Device) is a single-channel smart dimming controller which allows remote control of dimmable lights and dimming drivers through a mobile phone, tablet, PC, or home automation system. It can work standalone in a local Wi-Fi network or it can also be operated through cloud home automation services. The Device can be accessed, controlled, and monitored remotely from any place where the User has internet connectivity, as long as it is connected to the Internet. Shelly Dimmer Gen3 has an embedded Web Interface which can be used to monitor and control the Device, as well as adjust its settings. The Device can be used as trailing edge dimmer switch, with or without neutral wire.

## Main features

- **No need for neutral:** The Device can be used without neutral wire
- **Bypass:** Bypass is required when the device is used without neutral and the load is under 20 W. Bypass could help when there is light coming from the lamp even when it is turned off.
- **Groups of lights:** Groups of lights can be used, but they should have the same consumption (should have the same model and producer)
- **Bluetooth:** The Device complies the Bluetooth standard and can connect with other Bluetooth devices to exchange data in short range.

- **BLE Gateway:** Facilitates communication between BLE and Wi-Fi-enabled devices.
- **Wi-Fi:** The Device can connect to a wireless network.
- **Wi-Fi Range extender:** Retransmits the Wi-Fi signal and extends its reach.
- **Scripting:** Allows creating automation scenarios through scripts.
- **Basic Schedules:** Supports weekly schedules and routines, including setting of brightness, transition duration, and flip value of the dimming signal.
- **Advanced Schedules:** Supports detailed schedules and routines throughout the year with a broad range of time adjustments from seconds to months, including setting of brightness, transition duration, and flip value of the dimming signal.
- **Auto on/off timers:** Enables auto on/off timer setting.
- **Local actions:** Allows creating automation scenarios within the local Wi-Fi network, including setting of brightness, transition duration, and flip value of the dimming signal.
- **Webhooks:** Supports automation through lightweight, event-driven communication with other devices.
- **Compatibility:** Highly compatible with 3rd Party home automation systems.
- **No need for hub:** Ready for use locally or remotely via Shelly Smart Control or 3rd Party systems.
- **Activity log:** Stores detailed history of events.
- **KVS (Key-value storage):** KVS service provides a basic persistent storage of key-value pairs.
- **Safety:** Over current/voltage/power protections. When the device is used without neutral wire, those protections might not work properly.
- **Power measurement:**
  - Information about voltage (V), current (A) and consumption (W) is displayed when the device is used with neutral.
  - Power consumption cannot be measured when the device is used without neutral.
- **Night Mode:** Enables to set a specific brightness of input lights during nighttime.
- **Transition duration:** Controls the time for dimming from 0 to 100 % on toggle On and from 100 to 0% on toggle Off.
- **Minimum brightness on toggle On:** Brightness level (in percent) applied when there is a toggle On and current brightness is lower than 'Min brightness on toggle'. Default is 3%. Not applied when explicit (custom) transition is defined in Schedules and Actions.
- **Min/Max brightness:** Reframes the range of the dimming signal to get more precise brightness control on the output.
- **Switch/Button input mode:** Allows flexible input control through switches and/or buttons
  - One button dimming control
  - Dual button dimming control
- **Button fade rate:** Controls how quickly the output brightness changes while holding the button(s). Default is 3x.
- **Button presets:** State to be applied on double-push (double-click) event. Default value is 100%

- **Automatic dimming calibration:** Provides smooth dimming throughout the entire range. Must be performed on a new device, after a factory reset and after every change of the load.
  - On a new/factory reset device the calibration is started on the first toggle (through physical switch/button, mobile application, local web UI or rpc command)
  - Calibration can be started with simultaneous long-push for 5 seconds of the two buttons. The calibration lasts no more that 2 minutes and on success the light is On for 10 seconds, then goes off. If the calibration is not successful, the light flashes 5 times (1 sec ON, 1 sec OFF)
- **Factory reset through switch/button:** 5 consecutive toggles through switch/button in the 60 seconds timeframe after the device has been powered On will perform factory reset.
- **Virtual components:** A special set of components that do not exist in the device initially and are created dynamically by the user.
- **KNX:** Supports **KNXnet/IP** communication

## Use cases

- Retrofit your existing lighting system with the Dimmer Gen3 even if there is no neutral wire and continue using your current switches and electrical installation.
- Control brightness of dimmable lights to set the perfect brightness.
- Create smart schedules to have lights automatically adjust their brightness throughout the day.
- Sync your lights with sunrise and sunset times easily using smart schedules.
- Activate a night mode for reduced brightness during nighttime hours.
- Integrate the Dimmer Gen3 with third-party systems like Home Assistant, Google Home, Alexa, and SmartThings for expanded control options.
- Utilize the device to dim lights up or down with a single or double button press.
- Enhance the safety by creating actions to have the lights automatically on when Shelly Motion detects movement.

## Main applications

- Residential
- MDU (Multi Dwelling Units - apartments, condominiums, hotels, etc.)...
- Light commercial (small office buildings, small retail/restaurant/gas station, etc.)...
- Government/municipal
- University/college

## Integrations

### Amazon Alexa supported capabilities

Yes

## Google Smart Home supported traits

Yes

## Samsung SmartThings supported capabilities

Yes

## Simplified internal schematics

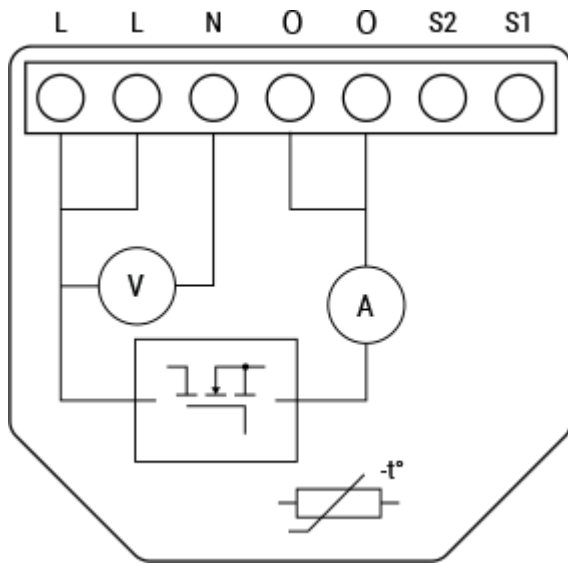

## Device electrical interfaces

### Inputs

- 2 switch/button inputs on screw terminals: **S1** and **S2**
- 3 power supply inputs on screw terminals: 1 **N** and 2 **L**

### Outputs

- Internally bridged outputs on screw terminals: **O**

### Add-on interface

Not supported

## Connectivity

- Wi-Fi
- Bluetooth

# Safety functions

- Overheating protection
- Overpower protection\*
- Overvoltage protection\*
- Undervoltage protection\*
- Overcurrent protection

\* Works only when used with Neutral.

# Supported load types

- Dimmable LED lamps: up to 150 W
- Incandescent bulbs: up to 200 W
- Halogen lamps: up to 200 W
- Iron-core transformer with low-voltage incandescent lamps: up to 200 VA
- Dimmable electronic transformers: up to 200 W

# User interface

## Inputs

- One (Control) button
  - Press and hold for 5 seconds to enable Device access point and Bluetooth connection.
  - Press and hold for 10 seconds to factory reset the Device.

## Outputs

- LED (monocolor) indication
  - AP (Access Point) enabled and Wi-Fi disabled:  
1 second ON / 1 second OFF
  - Wi-Fi enabled, but not connected to a Wi-Fi network:  
1 second ON / 3 seconds OFF
  - Connected to a Wi-Fi network:  
Constantly ON
  - Cloud is enabled, but not connected:  
1 second ON / 5 seconds OFF
  - Connected to Shelly Cloud:  
Constantly ON

- OTA (Over the Air Update):  
½ sec ON / ½ second OFF
- Button pressed and held for 5 seconds:  
½ second ON / ½ second OFF
- Button presses and held for 10 seconds:  
¼ second ON / ¼ second OFF

The list above starts with the initial device status and the lowest priority. Every next state cancels the previous one.

## Specifications

Quantity	Value
<b>Physical</b>	
Size (HxWxD):	38x42.5x16.5 mm / 1.50x1.67x0.65 inch
Weight:	24.3 g / 0.86 oz
Screw terminals max torque:	0.4 Nm / 3.5 lbin
Conductor cross section:	0.5 to 4 mm <sup>2</sup> / 20 to 11 AWG (solid, stranded, and bootlace ferrules)
Conductor stripped length:	5 to 6 mm / 0.20 to 0.24 in
Mounting:	In-wall
Shell material:	Plastic
Shell color:	Shell: Lime Print: Black
Connector color:	Black
<b>Environmental</b>	
Ambient working temperature:	-20 °C to 40 °C / -5 °F to 105 °F
Humidity:	30 % to 70 % RH
Max. altitude:	2000 m / 6562 ft
<b>Electrical</b>	
Power supply:	220-240 V~ 50 Hz
Power consumption:	< 1.5 W
Neutral not needed:	Yes

Min. load without neutral and without a Bypass:	20 W
Dimming type	Trailing edge
External protection:	16 A, tripping characteristic B or C, 6 kA interrupting rating, Energy limiting class 3
Short circuit protection	Yes
<b>Output circuits ratings</b>	
Max. output power:	200 W
<b>Sensors, meters*</b>	
Voltmeter range (AC):	180 V - 240 V
Voltmeter accuracy:	± 5 % (when used with neutral)
Ammeter range (AC)	0 A - 3 A,
Ammeter accuracy:	± 5 % (when used with neutral)
Internal-temperature sensor:	Yes
*Precise measurement is possible only when used with neutral.	
<b>Radio</b>	
<b>Wi-Fi</b>	
Protocol:	802.11 b/g/n
RF band:	2412 - 2472 MHz
Max. RF power:	< 20 dBm
Range:	Up to 30 m / 100 ft indoors and 50 m / 160 ft outdoors (Depends on local conditions)
<b>Bluetooth</b>	
Protocol:	4.2
RF band:	2402 - 2480 MHz
Max. RF power:	< 4 dBm
Range:	Up to 10 m / 33 ft indoors and 30 m / 100 ft outdoors (Depends on local conditions)

Microcontroller unit	
CPU:	ESP32 C3 STM32 G051
Clock frequency:	ESP32 C3: 40 Mhz
Flash:	8 MB
Firmware capabilities	
Schedules:	20
Webhooks (URL actions):	20 with 5 URLs per hook...
Scripting:	Yes
MQTT:	Yes
Advanced schedules:	Yes
KVS (Key-Value Store):	Yes

## Basic wiring diagrams

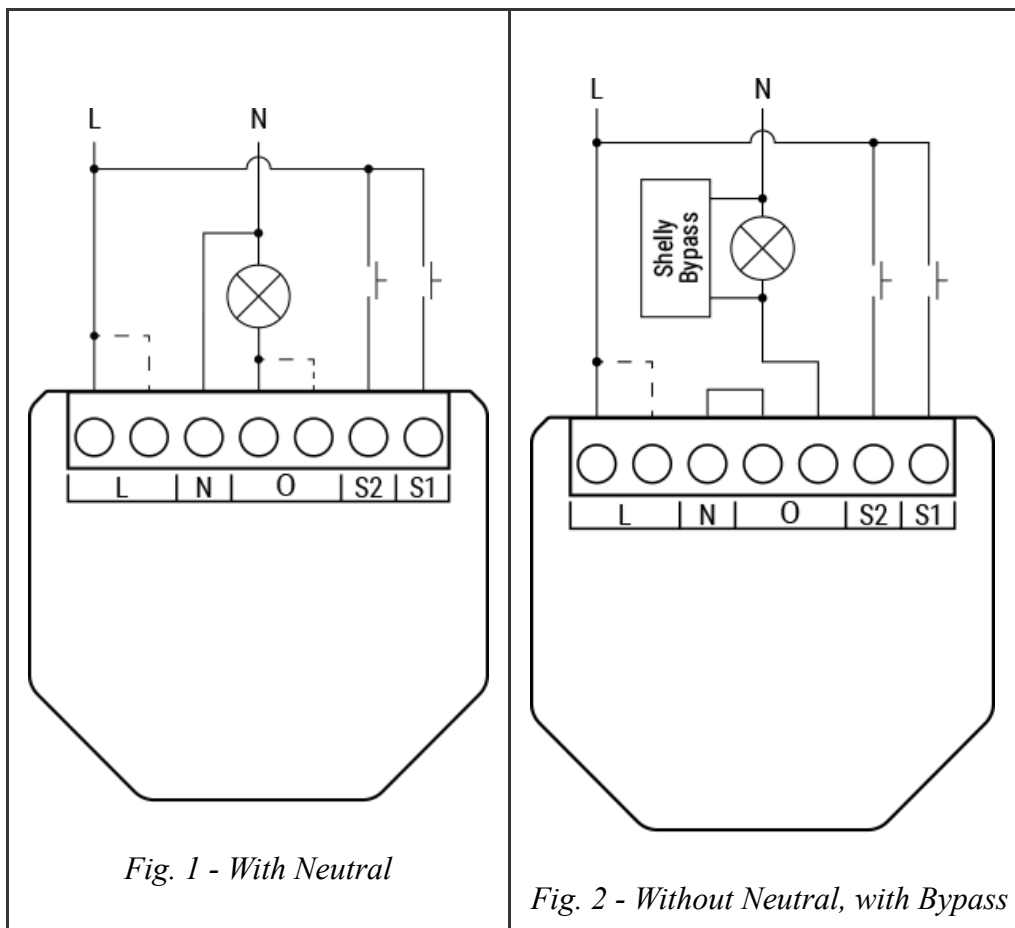

# Legend

Terminals		Wires	
L (x2)	2 live terminals	L	Live (220-240 V~) wire
N	Neutral terminal	N	Neutral wire
O (x2)	2 output terminals to the load		
S1, S2	Switch/button input terminals for light control		

## Shelly Smart Control

- [Adding the device to the Shelly Smart Control](#)

## Shelly Web user interface

- [Shelly Dimmer Gen3 Web user interface guide](#)

## Components and APIs

- [This device](#)
- [All Shelly devices and services](#)

## Compliance

[Shelly Dimmer Gen3 multilingual EU declaration of conformity 2025-07-22.pdf](#)

[Shelly Dimmer Gen3 UK PSTI ACT Statement of compliance.pdf](#)

[Compliance archive](#)

[Shelly Dimmer Gen3 multilingual EU declaration of conformity 65 2024-12-27.pdf](#)

## Printed user guide

[Shelly Dimmer Gen3 multilingual printed user and safety guide.pdf](#)

- [Ръководство за употреба и безопасност](#)

## Installation guides