

Wave Pro Shutter EU



Device identification

Device: Wave Pro Shutter

EU Part number/Ordering Code: QPSH-0A1P10EU

Z-Wave Product type ID: 0x0003

Z-Wave Product ID: 0x0084

Z-Wave Manufacturer: Shelly Europe Ltd.

Z-Wave Manufacturer ID: 0x0460

Terminology

- **Device** - In this document, the term “**Device**” is used to refer to the Shelly Qubino device that is a subject of this guide.
- **Gateway (GW)** - A Z-Wave™ gateway, also referred to as a Z-Wave™ controller, Z-Wave™ main controller, Z-Wave™ primary controller, or Z-Wave™ hub, etc., is a device that serves as a central hub for a Z-Wave™ smart home network. The term “**gateway**” is used in this document.
- **S button** - The Z-Wave™ Service button, located on Z-Wave™ devices and is used for various functions such as adding (inclusion), removing (exclusion), and resetting the device to its factory default settings. The term “**S button**” is used in this document.
- **Adding/Inclusion** - The process of adding Z-Wave device to a Z-Wave network - gateway. The words **included**, **added**, etc. are used in this regard.

- **Removing/Exclusion** - The process of removing Z-Wave device from a Z-Wave network - gateway. The words **excluded**, **removed**, etc. are used in this regard.

Short description

The Device is a DIN rail mountable and enables remote control of motorized blinds, roller shutters, venetian blinds, awnings, etc. It measures power consumption of the connected device. It is recommended to use only motors with electronic or mechanical limit switches. The motor limit switches must be set correctly before connecting the Device to the motor.

Manual operation for Shutter

[click here](#) to expand the details fo the manual operational instructions

Manual operation for Shutter with momentary switch

Parameter No. 71 set to 0 and Parameter No. 1 set to 0.

Pressing the push-button connected to SW1 (up) for less than 0,5 second (short press) will initiate the upward movement.

Pressing the push-button connected to SW2 (down) for less than 0,5 second (short press) will initiate the downward movement.

If the Shutter is moving, any press (on any push-button) will stop the movement.

Pressing the push-button connected to SW1 (up) for more than 0,5 second (long press) will initiate the upward movement until the push-button is released.

Pressing the push-button connected to SW2 (down) for more than 0,5 second (long press) will initiate the downward movement until the push-button is released.

Action on push-button	Blind is not moving	Blind is moving up	Blind is moving down	Tilting the slats of venetian blind is ongoing
Short press (less than 0,5 seconds) in the UP direction	Starts moving the blind upwards	Stops moving the blind	Stops moving the blind	No action
Short press (less than 0,5 seconds) in the DOWN direction	Starts moving the blind downwards	Stops moving the blind	Stops moving the blind	No action
Press and hold (longer than 0,5 seconds) in the UP direction	Starts moving the blind upwards. In case of venetian blinds, this also includes tilting the slats.	Moving	Moving	Tilting the slats to the end and then moving the blind UP
Press and hold (longer than 0,5 seconds) in the DOWN direction	Starts moving the blind downwards. In case of venetian blind, this also includes tilting the slats.	Moving	Moving	Tilting the slats to the end and then moving the blind DOWN

Release the push-button after a long press	No action	Stops moving the blind	Stops moving the blind	Stops tilting the slats
--	-----------	------------------------	------------------------	-------------------------

Manual operation for Shutter with a toggle switch

Parameter No. 71 set to 0 and Parameter No. 1 set to 1.

Pressing the toggle switch connected to SW1 (up) will initiate the upward movement until the toggle switch is released.

Pressing the toggle switch connected to SW2 (down) will initiate the downward movement until the toggle switch is released.

Manual operation for venetian blinds with a momentary switch

Parameter No. 71 set to 1 and Parameter No. 1 set to 0.

General rules:

- Short press (< 0,5 seconds) initiates the blind movement
- Long press (> 0,5 seconds) initiates the slats movement

Pressing the push-button connected to SW1 (up) for less than 0,5 second (short press) will initiate the upward movement.

Pressing the push-button connected to SW2 (down) for less than 0,5 second (short press) will initiate the downward movement.

If the Shutter is moving, any press (on any push-button) will stop the movement.

Pressing the push-button connected to SW1 (up) for more than 0,5 second (long press) will initiate the slats rotation (0 to 100%) until the push-button is released or the end rotation position is reached. The rotation time is defined in the Parameter No. 72.

Pressing the push-button connected to SW2 (down) for more than 0,5 second (long press) will initiate the slats rotation (100 to 0%) until the push-button is released or the end rotation position is reached. The rotation time is defined in the Parameter No. 72.

Action on push button	Blind is not moving	Blind is moving up	Blind is moving down	Tilting the slats of venetian blind is ongoing
Short press (less than 0,5 seconds) in the UP direction	Starts moving the blind upwards	Stops moving the blind	Stops moving the blind	Stops tilting the slats
Short press (less than 0,5 seconds) in the DOWN direction	Starts moving the blind downwards	Stops moving the blind	Stops moving the blind	Stops tilting the slats
Press and hold (longer than 0,5 seconds) in the UP direction	Starts tilting the slats	No action	No action	Tilting the slats until the rotation is complete

Press and hold (longer than 0,5 seconds) in the DOWN direction	Starts tilting the slats	No action	No action	Tilting the slats until the rotation is complete
Release the button after long press	No action	Stops moving the blind	Stops moving the blind	Stops tilting the slats

Manual operation for venetian blinds with a toggle switch

Parameter No. 71 set to 1 and Parameter No. 1 set to 1.

Pressing a toggle switch connected to SW1 (up) will initiate the upward movement, until the toggle switch is released.

Pressing a toggle switch connected to SW2 (down) will initiate the downward movement, until the toggle switch is released.

When the slats are at 100% position and the UP is pressed quickly, the blind will move up.

When the slats are at 0% position and the DOWN is pressed quickly, the blind will move down.

Slats positioning

To reach the maximum precision of the slats positioning when the blind is stopped by a push-button, gateway or when controlled by a gateway the slats will perform additional movement described below.

When the slats are set in any intermediate position and receive the command for a different position, the slats always move to the 100% position first and then back to the set position.

When the blind is moving DOWN, the slats are at 0% position. When the limit switch is reached, or the blind is stopped by a push-button or a gateway, the slats rotate to 100% and then move to the previous position (same as before the movement started).

When the blind is moving UP, the slats are at 100% position. When the blind is stopped by a push-button or a gateway, the slats rotate to the previous position (same as before the movement started).

Main applications

- Residential
- MDU (Multi Dwelling Units - apartments, condominiums, hotels, etc.)
- Light commercial (small office buildings, small retail/restaurant/gas station, etc.)
- Government/municipal
- University/college
- Farming

Integrations

Shelly Qubino Wave devices are developed on the **world's leading technology for smart homes – Z-Wave**.

This means Shelly Qubino Wave works with all **certified** gateways supporting Z-Wave communication protocol.

To make sure the functions of Shelly Qubino Wave products are supported on your gateway, we are regularly executing compatibility tests of our devices with different Z-Wave gateways.

Simplified internal schematics

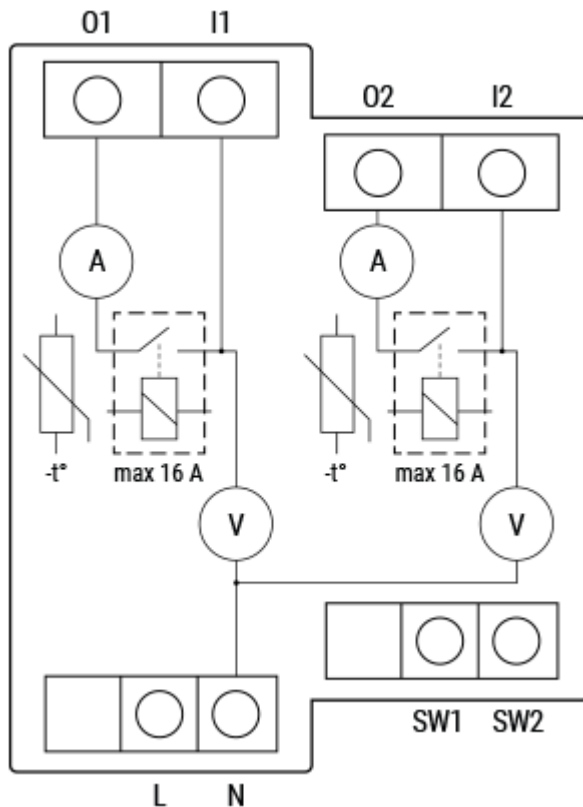

Device electrical interfaces

Inputs

- 2 switch/button input on screw terminal
- 2 power supply inputs on screw terminals: N and L

Outputs

- 2 relay output with power measurement on screw terminal

Connectivity

Z-Wave - Unsecure, S0 Security, S2 Unauthenticated Security, S2 Authenticated Security

Safety features

Over-load detection

Overheat detection

Supported load types

- Resistive (incandescent bulbs, heating devices)
- Capacitive (capacitor banks, electronic equipment, motor start capacitors)
- Inductive with RC Snubber (LED light drivers, transformers, fans, refrigerators, air-conditioners)

User interface

S button and operating modes

1. Normal mode
2. Setting in progress mode
3. Setting mode (with S button)
 - Settings mode is required to start desired procedure for example: adding (inclusion), removing (exclusion), factory reset etc. It has a limited time of operation. After the procedure in Setting mode is concluded, the Device goes automatically into Normal mode.
 - Entering to Setting mode:
 - Quickly press and hold the S button on the Device until the LED turns solid blue
 - An additional quick press on the S button means menu change in infinite loop
 - Menu LED status has a timeout of 10s before entering again into Normal state

S button's functions

- Manually adding the Device to a Z-Wave network
- Manually removing the Device from a Z-Wave network
- Factory Reset the Device

Functionality

Automatic calibration is a process during which the Device learns the position of the limit switches.



Note! For the correct position operation, the Device must perform a **calibration procedure!**
Note! The motor must be equipped with electronic or mechanical limit switches and the limit positions must be set correctly before calibration!

Shutter positioning calibration (Shutter mode)

Parameter No. 71 set to 0.

Calibration with the gateway

3-> default setting (after factory reset) - Parameter 78

1-> start calibration

2-> device is calibrated

3-> device is not calibrated

4-> calibration error

Start calibration:

1. Add the Device to the Z-Wave network according to the instructions for inclusion.
2. Set the Parameter No. 78 (forced Shutter calibration) value to 1.
3. The Device performs the calibration process, completing a full cycle – up, down, up, and down to 50%.
4. Check the Parameter No. 78 to see if the calibration was successfully executed (value 2).
5. Make sure that the yellow LED is not blinking.

i Note! *In case of values 3 or 4, check if the Device performs the complete cycle of moving (up, down, up, and down to 50%), if the limit switches are set correctly and if the wiring is done according to instructions in the user guide.*

Calibration with the push-button (SW1)

1. Move blind to the top (upper) position.
2. Press SW1 4 times in 3 seconds.
3. The Device will start calibration and complete 4 cycles: up, down, up, and down to 50%.
4. Calibration using SW1 is not time-limited!

Calibration with the S button

1. Enter the Setting mode by pressing the S button for less than 0,5 s (short press).
2. Keep pressing the S button until the calibration is selected, indicated by the yellow LED color.
3. Start the calibration by pressing the S button for more than 2 s.
4. Make sure that the yellow LED is not blinking.

i Note! *If the yellow LED is still blinking, check if the Device performs the complete cycle of moving (up, down, up, and down to 50%), if the limit switches are set correctly and if the wiring is done according to instructions in the user guide.*

Slats tilting position calibration (Venetian mode)

Parameter No. 71 set to 1.

When enabling the “venetian blind” mode, position calibration for slats titling must be done. After that, the position and angle of the slats can be set. By default, the rotation time of slats is set to 1,5 s. This value can be changed with the Parameter No. 72.

1. Add (include) and perform the Device calibration process according to the ‘Shutter positioning calibration’ section.

2. Set the Parameter No. 71 to 1 “Venetian blinds”.
3. By default, the full rotation time is set to 1,5 s. If this time is too long (if the blind starts to move up or down after the slats full cycle), decrease this time with the Parameter No. 72. If this time is too short (if the slats do not turn for a full cycle), increase this time with the Parameter No. 72.
4. Repeat the 3rd step until the position of the slats is correct.

i Note! If the turning time is set correctly, slats setting should not move blinds up or down.

LED Signalisation

Click to see LED signalisation

General rules

- To switch between Normal and Setting modes, press the S button once.
- **Solid LED** means that the Device is in **Setting mode** (this does not apply to plugs). When the Device is in Setting mode, it automatically switches to Normal mode after 10s.
- If the LED is not in Alarm mode, it will turn off after a timeout of 30 min (this does not apply to plugs). Press on the S button or Device power cycle wakes the LED up for 30 min.

Normal mode LED status: Normal mode is defined by a stable Device function that can last infinitely long.

Normal mode

Removed/Excluded / not calibrated

The LED will be blinking **blue** in Mode 1 for 10 min after every power cycle and 10 min after S button pressed.



Removed/Excluded / calibrated

The LED will be blinking **blue** and **yellow** in Mode 1 for 30 min after every power cycle and 10 min after S button pressed.



Added/Included / not calibrated

The LED will be blinking **green** in Mode 1 for 10 min after every power cycle and 10 min after S button pressed.



Added/Included / calibrated

The LED will be blinking **green** and **yellow** in Mode 1 for 30 min after every power cycle and 10 min after S button pressed.



Settings in progress

Factory reset and reboot

During factory reset, the LED will turn solid **green** for approx. 1sec, then the **blue** and **red** LED will be blinking 0,1s On, 0,1s Off for about 2sec.

Adding / Removing

During adding or removing, the LED will be blinking **blue** in Mode 2.

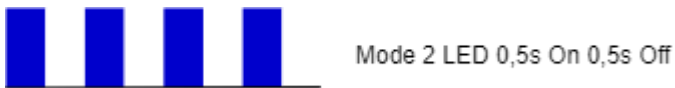

Shutter calibration

During the calibration, the LED will be blinking **yellow** in Mode 2.

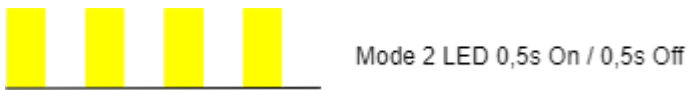

Settings mode with S button

Adding / Removing menu selected

When the menu is selected the LED will be on **blue**, for maximum of 10 seconds.

Adding / Removing menu - while pressing S- button - Add/Remove process selected

When the menu is executing the LED will be blinking **blue** in Mode 3.

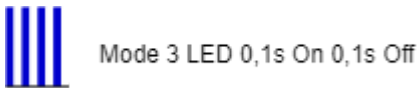

Factory reset menu selected

When the menu is selected the LED will be on **red**, for maximum of 10 seconds.

Factory reset - while pressing S - button - Factory reset process selected

When the menu is executing the LED will be blinking **red** in Mode 3.

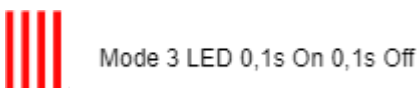

Calibration menu selected

When the menu is selected the LED will be on **yellow**, for maximum of 10 seconds.

Calibration - while pressing S - button - Calibration process selected

When the menu is executing the LED will be blinking **yellow** in Mode 3.



Alarm Mode

Over-current detected

The LED will be blinking **red** in Mode 4 1x - 0,2s On 0,2s Off 2s Off and repeating this sequence



Overheat detected

The LED will be blinking **red** in Mode 4 - 2x (LED 0,2s On / 0,2s Off) + 2s Off and repeating this sequence



Power supply fault (power supply 230 V AC frequency or 24 V DC voltage fault)

The LED will be blinking **red** in Mode 4 - 3x (LED 0,2s On / 0,2s Off) + 2s Off and repeating this sequence



LED blinking modes

Click to see the LED blinking modes

LED blinking modes	
Mode 1	0,5s On/2s Off
Mode 2	0,5s On/0,5s Off
Mode 3	0,1s On/0,1s Off
Mode 4	(1x to 6x - 0,2s On/0,2s Off) + 2s Off
Mode 5	0,2s On blue/0,2s On red

Specifications

Power supply	110 - 240 V~50/60 Hz
Power consumption	< 0.3 W
Power measurement [W]	Yes
Max. switching voltage AC	240 V
Max. switching current AC	16 A per channel
Overheating protection	Yes
Overcurrent protection	Yes
Overvoltage protection	Yes
Distance	Up to 40 m indoors (131 ft.) (depends on local condition)
Z-Wave® repeater:	Yes
CPU	Z-Wave® S800
Z-Wave® frequency bands	868.4 MHz
Maximum radio frequency power transmitted in frequency band(s)	< 25 mW
Size (H x W x D)	94x19x69 ± 0.5 mm / 3.70x0.75x2.71 ± 0.02 in
Weight	75 g / 2.65 oz.
Mounting	DIN rail
Screw terminals max. torque	0.4 Nm / 3.54 lbin
Conductor cross section	0.5 to 2.5 mm ² / 20 to 14 AWG (green connector) 0.5 to 1.5 mm ² / 20 to 16 AWG (white connectors)
Conductor stripped length	6 to 7 mm / 0.24 to 0.28 in (green connector) 5 to 6 mm / 0.20 to 0.24 in (white connectors)
Shell material	Plastic
Color	Black
Ambient temperature	-20°C to 40°C / -5°F to 105°F

Humidity	30% to 70% RH
Max. altitude	2000 m / 6562 ft.

Basic wiring diagram

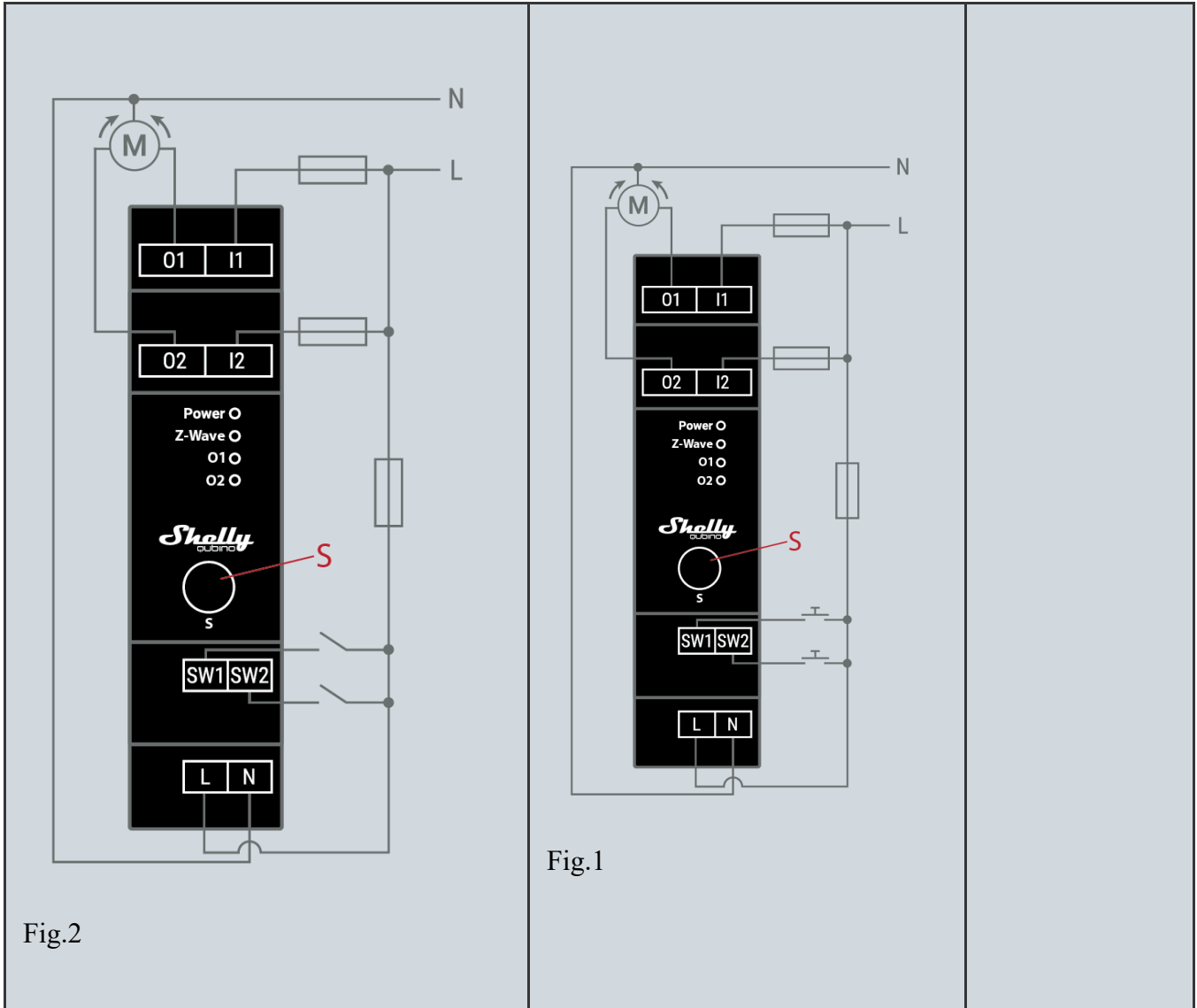

Legend

Device terminals:

- **N:** Neutral terminal
- **L:** Live terminal(s) (110-240 V AC)
- **SW1:** Input terminal for switch/push-button UP (open)
- **SW2:** Input terminal for switch/push-button DOWN (close)
- **I1:** Input terminal for motor UP (open)
- **I2:** Input terminal for motor DOWN (close)
- **O1:** Output terminal for motor UP (open)

- **O2:** Output terminal for motor DOWN (close)
Wires:
- **N:** Neutral wire
- **L:** Live wire (110-240 V AC)
Button:
- **S:** S button

About Z-Wave

Adding the Device to a Z-Wave® network (inclusion)

Click to see how to add, remove and reset the Device

- **Note!** *The blind connected to the Device will move 2s up/2s down if the Device is successfully added to/removed from a Z-Wave® network.*
- **Note!** *In case of Security 2 (S2) adding (inclusion), a dialog will appear asking you to enter the corresponding PIN Code (5 underlined digits) that are written on the Z-Wave® DSK label on the side of the Device and on the Z-Wave® DSK label inserted in the packaging.
IMPORTANT: The PIN Code must not be lost.*

SmartStart adding (inclusion)

SmartStart enabled products can be added into a Z-Wave® network by scanning the Z-Wave® QR Code present on the Device with a gateway providing SmartStart inclusion. No further action is required, and the SmartStart device will be added automatically within 10 minutes of being switched on in the network vicinity.

1. With the gateway application scan the QR code on the Device label and add the Security 2 (S2) Device Specific Key (DSK) to the provisioning list in the gateway.
2. Connect the Device to a power supply.
3. Check if the **blue** LED is blinking slowly. If so, the Device is not added to a Z-Wave® network.
4. Adding will be initiated automatically within a few seconds after connecting the Device to a power supply, and the Device will be added to a Z-Wave® network automatically.
5. The **blue** LED will be blinking faster during the adding process.
6. The **green** LED will be blinking in slowly if the Device is successfully added to a Z-Wave® network.

Adding (inclusion) with the S button

1. Connect the Device to a power supply.
2. Check if the **blue** LED is blinking slowly. If so, the Device is not added to a Z-Wave® network.
3. Enable add/remove mode on the gateway.
4. To enter the Setting mode, quickly press and hold the S button on the Device until the LED turns solid **blue**.

5. Quickly release and then press and hold (> 2s) the S button on the Device until the **blue** LED starts blinking slowly. Releasing the S button will start the Learn mode.
6. The **blue** LED will be blinking faster during the adding process.
7. The **green** LED will be blinking slowly if the Device is successfully added to a Z-Wave® network.

Note! *In Setting mode, the Device has a timeout of 10s before entering again into Normal mode.*

Adding (inclusion) with a switch/push-button

1. Connect the Device to a power supply.
2. Check if the **blue** LED is blinking slowly. If so, the Device is not added to a Z-Wave® network.
3. Enable add/remove mode on the gateway.
4. Toggle the switch/push-button connected to any of the SW terminals (SW, SW1, SW2, etc.) 3 times within 3 seconds (this procedure puts the Device in Learn mode*). The Device must receive on/off signal 3 times, which means pressing the momentary switch 3 times, or toggling the switch on and off 3 times.
5. The **blue** LED will be blinking faster during the adding process.
6. The **green** LED will be blinking slowly if the Device is successfully added to a Z-Wave® network.

***Learn mode** - a state that allows the Device to receive network information from the gateway.

Removing the Device from a Z-Wave® network (exclusion)

Note! *The Device will be removed from your Z-Wave® network, but any custom configuration parameters will not be erased.*

Note! *The blind connected to the Device will move 2s up/2s down if the Device is successfully added to/removed from a Z-Wave® network.*

Removing (exclusion) with the S button

1. Connect the Device to a power supply.
2. Check if the **green** LED will be blinking slowly. If so, the Device is added to a Z-Wave® network.
3. Enable add/remove mode on the gateway.
4. To enter the Setting mode, quickly press and hold the S button on the Device until the LED turns solid **blue**.
5. Quickly release and then press and hold (> 2s) the S button on the Device until the **blue** LED starts blinking slowly. Releasing the S button will start the LEARN MODE.
6. The **blue** LED will be blinking faster during the removing process.
7. The **blue** LED will be blinking slower if the Device is successfully removed from a Z-Wave® network.

Note! *In Setting mode, the Device has a timeout of 10s before entering again into Normal mode.*



Removing (exclusion) with a switch/push-button

1. Connect the Device to a power supply.
2. Check if the **green** LED will be blinking slowly. If so, the Device is added to a Z-Wave® network.
3. Enable add/remove mode on the gateway.
4. Toggle the switch/push-button connected to any of the SW terminals (SW, SW1, SW2,...) 3 times within 3 seconds (this procedure puts the Device in LEARN MODE). The Device must receive on/off signal 3 times, which means pressing the momentary switch 3 times, or toggling the switch on and off 3 times.
5. The **blue** LED will be blinking faster during the removing process.
6. The **blue** LED will be blinking slower if the Device is successfully removed from a Z-Wave® network.

Factory reset

Factory reset general

After Factory reset, all custom parameters and stored values (kWh, associations, routing, etc.) will return to their default state. HOME ID and NODE ID assigned to the Device will be deleted. Use this reset procedure only when the gateway is missing or otherwise inoperable.

Factory reset with the S button

Note! *Factory reset with the S button is possible anytime.*

1. To enter the Setting mode, quickly press and hold the S button on the Device until the LED turns solid blue.
2. Press the S button multiple times until the LED turns solid **red**.
3. Press and hold (> 2s) S button on the Device until the **red** LED starts blinking faster. Releasing the S button will start the factory reset.
4. During factory reset, the LED will turn solid **green** for about 1s, then the **blue** and **red** LED will start blinking faster for approx. 2s.
5. The **blue** LED will be blinking slower if the Factory reset is successful.

Factory reset with a switch/push-button

Note! *Factory reset with a switch/push-button is only possible within the first minute after the Device is connected to a power supply.*

1. Connect the Device to a power supply.
2. Toggle the switch/push-button connected to any of the SW terminals (SW, SW1, SW2,...) 5 times within 3 seconds. The Device must receive on/off signal 5 times, which means pressing the push-button 5 times,

or toggling the switch on and off 5 times.

3. During factory reset, the LED will turn solid **green** for about 1s, then the **blue** and **red** LED will start blinking faster for approx. 2s.
4. The **blue** LED will be blinking slower if the Factory reset is successful.

Z-Wave Security and Device Specific Key (DSK)

[Click to see about the Security and the DSK](#)

The Device supports the latest Security 2 (S2) feature. S2 is handled by the Strong AES 128 Encryption protocol, which means that the S2 makes Z-Wave® the most secure IoT (Internet of Things) security platform out there. To fully utilize the product and its Security 2 feature, a Security 2-enabled Z-Wave® gateway must be used.

Authenticated Control

- Out-Of-Band DSK for inclusion
- May be used by most implementations

The Device also supports Security 2 Authenticated, Unauthenticated, and Unsecure inclusion.

Note! When adding the Device to a Z-Wave® network with a gateway supporting Security 2 (S2), the PIN Code of the Z-Wave® Device Specific Key (DSK) is required. The unique DSK code is printed on the DSK label on the side of the Device and a copy is inserted in the packaging, which must not be lost. Do not remove the DSK label from the product. As a backup measure, use the label in the packaging.



The first five digits of the key are highlighted or underlined to help the user identify the PIN Code part of the DSK text. The DSK is additionally represented with a QR Code as shown on the image.

DSK label and QR code (example)

A joining node requesting to join the S2 Access Control Class or the S2 Authenticated Class will obfuscate its Public Key by setting the bytes 1..2 to zeros (0x00) before transferring its key via RF.

The DSK may be used for out-of-band (OOB) authentication.

- The including gateway may use a QR code scanning device to read the entire DSK of the joining device and match it with the obfuscated public key received via RF from the joining device.

Z-Wave Parameters

[Click to see the Parameters](#)

Parameter No. 1 – Push-button (momentary) / bistable (toggle switch) selection

With this parameter, you can select between the switch type: push-button (momentary) or on/off toggle switch connected to SW1 and SW2 inputs.

Value size: 1 Byte

Default value: 0

Values & descriptions:

- 0 - momentary switch
- 1 - toggle switch (contact closed - ON / contact opened - OFF)
- 2 - single, momentary switch (the switch should be connected to SW1 terminal)

NOTE: When set = 2, 1x click on SW1 up - 1x click on SW1 stop - 1x click down

Parameter No. 3 – Inputs orientation

This parameter allows to reverse the operation of switches connected to SW1 and SW2 inputs without changing the wiring.

Value size: 1 Byte

Default value: 0

Values & descriptions:

- 0 - default (SW1 - O1, I2 - O2)
- 1 - reversed (SW1 - O2, I2 - O1)

Parameter No. 5 – Output orientation

This parameter allows to reverse the operation of O1 and O2 without changing the wiring (in case of invalid motor connection) to ensure proper operation.

Value size: 1 Byte

Default value: 0

Values & descriptions:

- 0 - default (O1 - UP, O2 - DOWN)
- 1 - reversed (O1 - DOWN, O2 - UP)

Parameter No. 40 - Power Consumption Reporting

Choose by how much the power (W) consumption needs to increase or decrease to be reported. Values correspond to percentages, so if 50 is set (by default), the Device will report any power consumption changes of 50 % or more, compared to the last reading.

Values size: 1 Byte

Default value: 50

Values & descriptions:

- 0 - Power consumption reporting disabled

- 1 - 100 = 1 % - 100 % Power consumption reporting enabled. New value is reported only when the power consumption in real time changes by more than the percentage value set in this parameter, compared to the previous power consumption reading, starting at 1 % (the lowest value possible).

NOTE: Power consumption needs to increase or decrease by at least 1 Watt to be reported, REGARDLESS of the percentage set in this parameter.

Parameter No. 71 - Operating modes

Choose between the two operating modes. In shutter mode, you can select up/down/stop. In venetian mode, an additional widget/endpoint is displayed in the UI interface, which you can use to control the tilt position of the slats.

Values size: 1 Byte

Default value: 0

Values & descriptions:

- 0 - Shutter mode
- 1 - Venetian mode with (up/down and slats rotation)

Parameter No. 72 - Venetian blind slats turning time

Set the time required for the slats to make a full turn (180 degrees).

NOTE: Make sure that working mode is set to venetian (Par. No. 71 =1)

Values size: 2 Byte

Default value: 150 = 1.5 seconds

Values & descriptions:

- 0 - turning time disabled
- 1 - 32000 = 0.01 seconds – 320 seconds

NOTE: If the set time is too long and a full turn was already performed, the device will start moving up or down for the remaining time. In this case, shorten the turning time.

Parameter No. 73 - Slats position after moving

This parameter is used to enable/disable the slats to return to the previously set position, after being activated via the gateway, push-button operation or when the lower limit switch is reached.

Values size: 1 Byte

Default value: 1

Values & their descriptions:

- 0 - disable
- 1 – enable

NOTE: Make sure that working mode is set to venetian (Par. No. 71=1)

Parameter No. 76 - Motor operation detection

Define the power consumption threshold at the end positions. Based on this value, the Device will know that the shutters reached the limit switches.

Values size: 1 Byte

Default value: 1

Values & their descriptions:

- 0 - Disabled: reaching a limit switch will not be detected
- 1 - Auto power calibration
- 2 - 1-255 (1-255W) - report interval

NOTE: For correct auto power calibration the shutter calibration must be performed!

Parameter No. 78 – Forced shutter calibration

By setting this parameter to value 1 the Device will start executing force calibration procedure. The parameter also reports the calibration status by sending the get parameter value command.

NOTE: Check chapter Functionality with calibration details

NOTE: During the calibration procedure the blind moves up, down, up, and down to 50%.

NOTE: During the calibration procedure the yellow LED is blinking.

Values size: 1 Byte

Default value: 3 (after factory reset)

Values & their descriptions:

- 1 - start calibration
- 2 - device is calibrated (read only)
- 3 - device is not calibrated (read only)
- 4 - calibration error (read only)

Parameter No. 80 – Motor stop delay after limit switch detection

This parameter defines the delay time for the motor to turn off, after reaching the limit switch.

Values size: 1 Byte

Default value: 10

Values & their descriptions:

- Default value 10 = (1s)
- 0-127 (0-12.7s) - time

Parameter No. 85 – Power consumption max delay time

Define the maximum time before the power consumption of the motor is read from the Device, after one of the relays is switched on. If there is no power consumption during the set time (motor is not connected, damaged or requires longer time to start, motor is at the end position), the relay will switch off. This time is defined by entering it manually.

Values size: 1 Byte

Default value: 30

Values & descriptions:

- 0 = time is set automatically
- 3 - 50 = 0.3seconds – 5seconds (100ms resolution)

Parameter No. 91 - Max. Motor moving time

When the shutter is not calibrated (or the motor is not equipped with a limit switch), this parameter defines the movement time of the motor.

Values size: 2 Byte

Default value: 12000 (120 s)

Values & descriptions:

- value = 1 - 32000s

Z-Wave Command Class

Click to see the Command Classes

COMMAND_CLASS_ZWAVEPLUS_INFO_V2
COMMAND_CLASS_SWITCH_MULTILEVEL_V4
COMMAND_CLASS_ASSOCIATION_3
COMMAND_CLASS_MULTI_CHANNEL_ASSOCIATION_V4
COMMAND_CLASS_ASSOCIATION_GRP_INFO_V3
COMMAND_CLASS_NOTIFICATION_V9
COMMAND_CLASS_TRANSPORT_SERVICE_V2
COMMAND_CLASS_VERSION_V3
COMMAND_CLASS_MANUFACTURER_SPECIFIC_V2
COMMAND_CLASS_DEVICE_RESET_LOCALLY_V1
COMMAND_CLASS_INDICATOR_V4
COMMAND_CLASS_POWERLEVEL_V1
COMMAND_CLASS_SECURITY_V1
COMMAND_CLASS_SECURITY_2_V1
COMMAND_CLASS_MULTI_CHANNEL_V4
COMMAND_CLASS_SUPERVISION_V2
COMMAND_CLASS_FIRMWARE_UPDATE_MD_V7
COMMAND_CLASS_CONFIGURATION_V4
COMMAND_CLASS_SWITCH_BINARY_V2
COMMAND_CLASS_APPLICATION_STATUS_V2
COMMAND_CLASS_METER_V6

Endpoint 1:

Device Class:

BASIC_TYPE_ROUTING_SLAVE
GENERIC_TYPE_SWITCH_MULTILEVEL

SPECIFIC_TYPE_CLASS_B_MOTOR_CONTROL

Command Classes:

COMMAND_CLASS_ZWAVEPLUS_INFO_V2
COMMAND_CLASS_SWITCH_MULTILEVEL_V4
COMMAND_CLASS_ASSOCIATION_V3
COMMAND_CLASS_ASSOCIATION_GRP_INFO_V3
COMMAND_CLASS_MULTI_CHANNEL_ASSOCIATION_V4
COMMAND_CLASS_NOTIFICATION_V9
COMMAND_CLASS_SUPERVISION_V2
COMMAND_CLASS_SECURITY_V1
COMMAND_CLASS_SECURITY_2_V1
COMMAND_CLASS_SWITCH_BINARY_V2
COMMAND_CLASS_APPLICATION_STATUS_V1
COMMAND_CLASS_METER_V6

Endpoint 2:

Device Class:

BASIC_TYPE_ROUTING_SLAVE
GENERIC_TYPE_SWITCH_MULTILEVEL
SPECIFIC_TYPE_CLASS_B_MOTOR_CONTROL

Command Classes:

COMMAND_CLASS_ZWAVEPLUS_INFO_V2
COMMAND_CLASS_SWITCH_MULTILEVEL_V4
COMMAND_CLASS_ASSOCIATION_V3
COMMAND_CLASS_ASSOCIATION_GRP_INFO_V3
COMMAND_CLASS_MULTI_CHANNEL_ASSOCIATION_V4
COMMAND_CLASS_NOTIFICATION_V9
COMMAND_CLASS_SUPERVISION_V2
COMMAND_CLASS_SECURITY_V1
COMMAND_CLASS_SECURITY_2_V1
COMMAND_CLASS_SWITCH_BINARY_V2
COMMAND_CLASS_APPLICATION_STATUS_V1
COMMAND_CLASS_METER_V6

Endpoint 2 is supported by the module only when the Parameter No. 71 is set to the value 1.

Z-Wave Notifications Command Class

[Click to see the Notification Command Class](#)

Z-Wave® Notifications Command class

Wave Shutter supports the following notifications:

- In case of exceeding the power of >1100 W for more than 5 seconds, Shutter automatically turns off the output and the overload notification is sent.
- In case the exceeding the inside device temperature for more than 5s Shutter automatically turns off the output and the overtemperature notification is sent.

Notification Type	Notification Event
-------------------	--------------------

Power Management (0x08)	Over-load detected (0x08)
Heat alarm (0x04)	Overheat detected (0x02)

Z-Wave Associations

Click to see the Associations

Associations are used for direct communication between the Device and other devices within your Z-Wave network without the need of the Z-Wave gateway.

Max. number of associated devices per group is 9. This value is fixed and can not be configured. Each association group supports the association of up to 9 devices (nodes). To avoid network delays, we recommend limiting the amount of associated devices to no more than 5 per group. “Lifeline Group” is reserved solely for a gateway and hence only 1 node can be assigned.

Association group 1 – “Lifeline Group” reports the status of the Device status and allows to assign only one device (gateway by default); only 1 node is allowed. The following command classes are supported:

Root device

Association Group 1 - Lifeline

1. DEVICE_RESET_LOCALLY_NOTIFICATION : triggered upon request
2. SWITCH_BINARY_REPORT : status change report for all outputs O (O, O1, O2, ...) - common
3. NOTIFICATION_REPORT : triggered on Overheat
4. NOTIFICATION_REPORT : triggered on Over-load detected sum of all outputs O (O1+O2+...)
5. METER_REPORT : triggered according to Configuration parameters

Association Group 2

Allowed nodes: 9

It is assigned to switch connected to the SW 1 or SW1 terminal (uses Switch Multilevel command class).

Triggered by SW 1 or SW2 valid for Shutter mode.

Supports the following command classes:

- SWITCH_MULTILEVEL_START_LEVEL_CHANGE : initiate a transition to a new level (increase or decrease light intensity in case of dimmer, or move shutter up or down, ...)
- SWITCH_MULTILEVEL_STOP_LEVEL_CHANGE : stop an ongoing transition (stop increase or decrease light intensity in case of dimmer, or stop moving shutter up or down, ...)



It is recommended to use push buttons for this association.

Association Group 3

Allowed nodes: 9

It is assigned to switch connected to the SW (SW1) terminal (uses Switch Multilevel command class).

Triggered by SW 1 or SW2 valid for Venetian mode

Supports the following command classes:

- SWITCH_MULTILEVEL_START_LEVEL_CHANGE : initiate a transition to a new level (increase or decrease light intensity in case of dimmer, or move shutter up or down, ...)
- SWITCH_MULTILEVEL_STOP_LEVEL_CHANGE : stop an ongoing transition (stop increase or decrease light intensity in case of dimmer, or stop moving shutter up or down, ...)

 It is recommended to use push buttons for this association.

Association Group 4

Allowed nodes: 16

When blinds are moving up, Shutter will send Basic set ON command to associated device and associated device will turn ON. When blinds are moving down, Flush Shutter will send Basic set OFF command to associated device and the device will turn OFF.

Triggered at sensing moving direction of roller: up= FF, down = 00. Supports the following command classes:

- BASIC_SET : set On / Off state at the associated device

Association Group 5

Allowed nodes: 16

When blinds reach upper position, Shutter will send Basic set OFF command to associated device and the device will turn OFF. When blinds reach down position Flush Shutter will send Basic set ON command to associated device and the device will turn ON.

Triggered at sensing moving direction of roller: up= FF, down = 00. Supports the following command classes:

- BASIC_SET : set On / Off state at the associated device

Association Group 6

Allowed nodes: 9

It is assigned to switch connected to the SW 1 or SW1 terminal (uses Switch Multilevel command class).

Triggered by SW 1 or SW2 valid for Shutter mode.

Supports the following command classes:

- SWITCH_MULTILEVEL_START_LEVEL_CHANGE : initiate a transition to a new level (increase or decrease light intensity in case of dimmer, or move shutter up or down, ...)
- SWITCH_MULTILEVEL_STOP_LEVEL_CHANGE : stop an ongoing transition (stop increase or decrease light intensity in case of dimmer, or stop moving shutter up or down, ...)

 It is recommended to use push buttons for this association.

Association Group 7

Allowed nodes: 9

It is assigned to switch connected to the SW (SW1) terminal (uses Switch Multilevel command class).

Triggered by SW 1 or SW2 valid for Venetian mode

Supports the following command classes:

- SWITCH_MULTILEVEL_START_LEVEL_CHANGE : initiate a transition to a new level (increase or decrease light intensity in case of dimmer, or move shutter up or down, ...)
- SWITCH_MULTILEVEL_STOP_LEVEL_CHANGE : stop an ongoing transition (stop increase or decrease light intensity in case of dimmer, or stop moving shutter up or down, ...)

 It is recommended to use push buttons for this association.

Endpoint 1

Association Group 1 - Lifeline

1. SWITCH_BINARY_REPORT : status change report for output O (O1)
2. NOTIFICATION_REPORT : triggered on Over-current detected O (O1)
3. METER_REPORT : triggered by load power consumption connected to output O(O1) (according to the settings of Parameters No. 36 and 39)

Association Group 2

Allowed nodes: 9

It is assigned to switch connected to the SW 1 or SW1 terminal (uses Switch Multilevel command class).

Triggered by SW 1 or SW2 valid for Shutter mode.

Supports the following command classes:

- SWITCH_MULTILEVEL_START_LEVEL_CHANGE : initiate a transition to a new level (increase or decrease light intensity in case of dimmer, or move shutter up or down, ...)
- SWITCH_MULTILEVEL_STOP_LEVEL_CHANGE : stop an ongoing transition (stop increase or decrease light intensity in case of dimmer, or stop moving shutter up or down, ...)

 It is recommended to use push buttons for this association.

Association Group 3

Allowed nodes: 9

It is assigned to switch connected to the SW (SW1) terminal (uses Switch Multilevel command class).

Triggered by SW 1 or SW2 valid for Venetian mode

Supports the following command classes:

- SWITCH_MULTILEVEL_START_LEVEL_CHANGE : initiate a transition to a new level (increase or decrease light intensity in case of dimmer, or move shutter up or down, ...)
- SWITCH_MULTILEVEL_STOP_LEVEL_CHANGE : stop an ongoing transition (stop increase or decrease light intensity in case of dimmer, or stop moving shutter up or down, ...)

 It is recommended to use push buttons for this association.

Association Group 4

Allowed nodes: 16

When blinds are moving up, Shutter will send Basic set ON command to associated device and associated device will turn ON. When blinds are moving down, Flush Shutter will send Basic set OFF command to associated device and the device will turn OFF.

Triggered at sensing moving direction of roller: up= FF, down = 00. Supports the following command classes:

- BASIC_SET : set On / Off state at the associated device

Association Group 5

Allowed nodes: 16

When blinds reach upper position, Shutter will send Basic set OFF command to associated device and the device will turn OFF. When blinds reach down position Flush Shutter will send Basic set ON command to associated device and the device will turn ON.

Triggered at sensing moving direction of roller: up= FF, down = 00. Supports the following command classes:

- BASIC_SET : set On / Off state at the associated device

Endpoint 2

Association Group 1 - Lifeline

1. SWITCH_BINARY_REPORT : status change report for output O2
2. NOTIFICATION_REPORT : triggered on Over-load detected O2
3. METER_REPORT : triggered by load power consumption connected to output O2 (according to the settings of Parameters No. 37 and 40)

Association Group 2

Allowed nodes: 9

It is assigned to switch connected to the SW 1 or SW1 terminal (uses Switch Multilevel command class).

Triggered by SW 1 or SW2 valid for Shutter mode.

Supports the following command classes:

- SWITCH_MULTILEVEL_START_LEVEL_CHANGE : initiate a transition to a new level (increase or decrease light intensity in case of dimmer, or move shutter up or down, ...)
- SWITCH_MULTILEVEL_STOP_LEVEL_CHANGE : stop an ongoing transition (stop increase or decrease light intensity in case of dimmer, or stop moving shutter up or down, ...)



It is recommended to use push buttons for this association.

Association Group 3

Allowed nodes: 9

It is assigned to switch connected to the SW (SW1) terminal (uses Switch Multilevel command class).

Triggered by SW 1 or SW2 valid for Venetian mode

Supports the following command classes:

- SWITCH_MULTILEVEL_START_LEVEL_CHANGE : initiate a transition to a new level (increase or decrease light intensity in case of dimmer, or move shutter up or down, ...)

- SWITCH_MULTILEVEL_STOP_LEVEL_CHANGE : stop an ongoing transition (stop increase or decrease light intensity in case of dimmer, or stop moving shutter up or down, ...)

 It is recommended to use push buttons for this association.

Z-Wave Important disclaimer

Z-Wave® wireless communication may not always be 100% reliable. This Device should not be used in situations in which life and/or valuables are solely dependent on its functioning. If the Device is not recognised by your gateway or appears incorrectly, you may need to change the Device type manually and ensure that your gateway supports Z-Wave Plus™ multi-channel devices.

Troubleshooting

For troubleshooting please visit our support portal: <https://support.shelly.cloud/>

Compatibility with gateways

Wave Pro Shutter	functions - reports								
Gateway	Up	Down	SW Up	SW down	W	kWh	Slats	SW Slats	Notes
Home Assistant	✓	✓	✓	✓	✓	✓	✓	✓	
Fibaro HC 3 / Z-Wave engine 3	✓	✓	✓	✓	✓	✓	✓	✓	
Homey	✓	✓	✓	✓	✓	✓	✓	✓	
Homee Cube Gen 7	✓	✓	✓	✓	✓	✓	✗	✗	*1
Homee Cube Gen 5	✓ P	✓ P	P	P	✗	✗	✗	✗	*1, *2, *3
Smart Things	TBD	TBD	TBD	TBD	TBD	TBD	TBD	TBD	with the Shelly Wave edge driver
Vera Ezlo	✓	✓	✓	✓	✓	✓	✓	✓	
Cozify	✓	✓	✓	✓	✓	✓	✓	✓	
Notes	*1 The slats cannot be controlled through the UI and their position cannot be visualized due to the lack of control. *2 The reports from the UI are sent only using the buttons, the slider sends the device to the location but it does not refresh the state.								

	<p>*3 The state is refreshed only after the stop button is pressed. (valid for buttons connected to the SW and the slider in UI)</p> <p>*4 Device is sent to position but the position is not reported</p>
--	--

Legend	
Symbol	State
✓	Working / Possible
✗	Not Working / Not Possible
P	Partially
N/T	Not Tested
TBD	To be done

Function	Meaning / tested
On/Off	if device respond to the app UI On/Off command
SW On/Off	if device reports On/Off changes by SW input
Dimming	if device respond to app UI dimming command
SW Dimming	if device report dimming state change by SW input
Watts	if Watts are reported (unsolicited)
kWh	if kWh are reported (unsolicited)
Up/Down	if device respond to the app UI Up/Down command
SW Up/Down	if device reports Up/Down changes by SW input
Slats	if the slats respond to the app UI command
SW Slats	if the slats report the changes done by SW
D control	<i>detached mode</i> if device reports scene commands single press, double press,...
D Binary	<i>detached mode</i> if the device reports binary On/Off by SW input

Sensor #	Is the sensor report visualized in the gateway, type of sensor in the notes.
-----------------	--

Gateway guides

You may find useful guides on gateways in the Z-Wave [Shelly Knowledge base](#).

Compliance

- [Wave Pro Shutter multilingual EU declaration of conformity 2025-07-23.pdf](#)
- [Wave Pro Shutter UK PSTI ACT Statement of compliance.pdf](#)

Compliance archive

[Wave Pro Shutter multilingual EU declaration of conformity 44 2024-02-28.pdf](#)

Printed User Guide

[Wave Pro Shutter Ръководство за употреба и безопасност.pdf](#) [Wave Pro Shutter Ръководство за употреба и безопасност.pdf.pdf](#)