

Shelly Pro EM 50

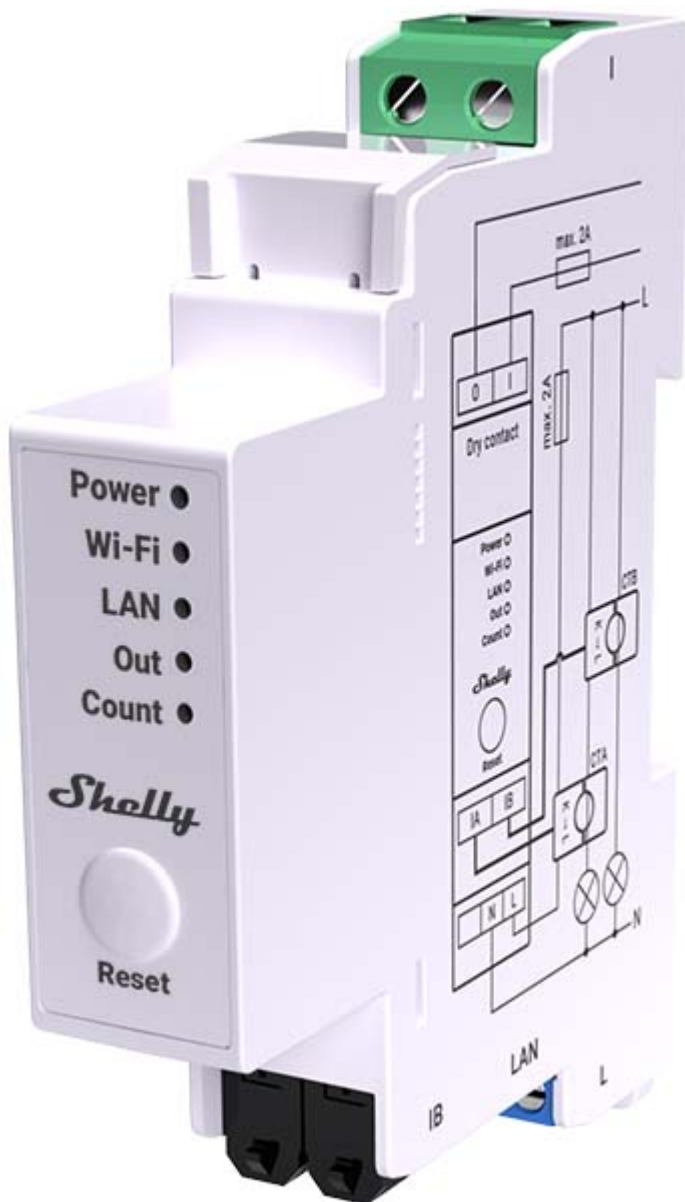

Device identification

- Device name: **Shelly Pro EM-50**
- Device model: **SPEM-002CEBEU50**
- Device SSID: **ShellyProEM50-XXXXXX**

Short description

Shelly Pro EM-50 (The Device) is a DIN rail mountable two-channel, single-phase energy meter. Enhanced with all the gen2 firmware flexibility and LAN connectivity, it provides professional integrators with additional options for end-customer solutions. It can work standalone in a local LAN and/or Wi-Fi network, or it can also be operated through cloud home automation services through MQTT, HTTP, and WebSocket. All inbound connections support TLS.

The Device reports accumulated energy as well as instantaneous voltage, current, active, and apparent power per phase in real time. It stores data in non-volatile memory that can be retrieved for a period of up to 60 days in 1-minute intervals.

The Device has a real-time clock to keep the correct time if the connection to an SNTP server is lost.

Shelly Pro EM-50 can be accessed, set up, and monitored remotely by the User, as well as the Device can access and communicate with an automation system, as long as they are in the same network infrastructure.

The Device has an embedded Web Interface which can be used to monitor and control the device, as well as adjust its settings.

The Device has a built-in relay for contactor control.

Features

- 4 Quadrant measurement
- DIN rail mounting
- Current transformer connection
- External contactor control via built in dry-contact relay
- Optical pulse indication of energy usage
- Real-time clock
- Data logs
- Accuracy Class B (active energy)¹
- Photovoltaic ready

¹ *The Device has a measurement accuracy of 1%, based on internal design validation and testing.*

Main applications

- Residential
- MDU (Multi Dwelling Units - apartments, condominiums, hotels, etc.)
- Light commercial (small office buildings, small retail/restaurant/gas station, etc.)
- Agricultural (farms, barns, silos, etc.)
- Government/municipal
- University/college

Simplified internal schematics

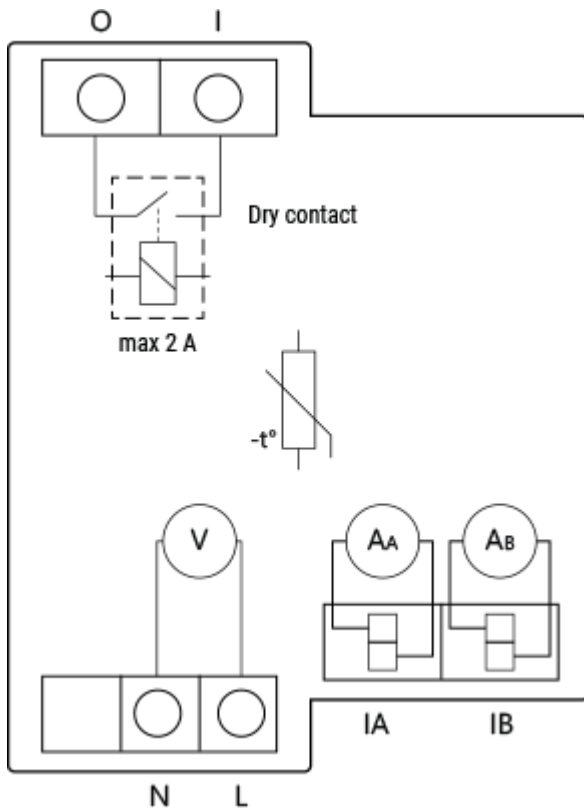

Device electrical interfaces

Inputs

- 2 line inputs on screw terminals: 1 **L** and 1 **N**
- 2 current transformer inputs: **IA** and **IB** for current measurement

Outputs

- 2 galvanically isolated relay terminals: **I** and **O**

Ethernet port

- 1 RJ45 connector

⚠CAUTION! Plug in or unplug the LAN cable only when the Device is powered off! The LAN cable connector must not be metallic in the parts touched by the user to plug in or unplug the cable.

Add-on interface

- Shelly proprietary serial interface

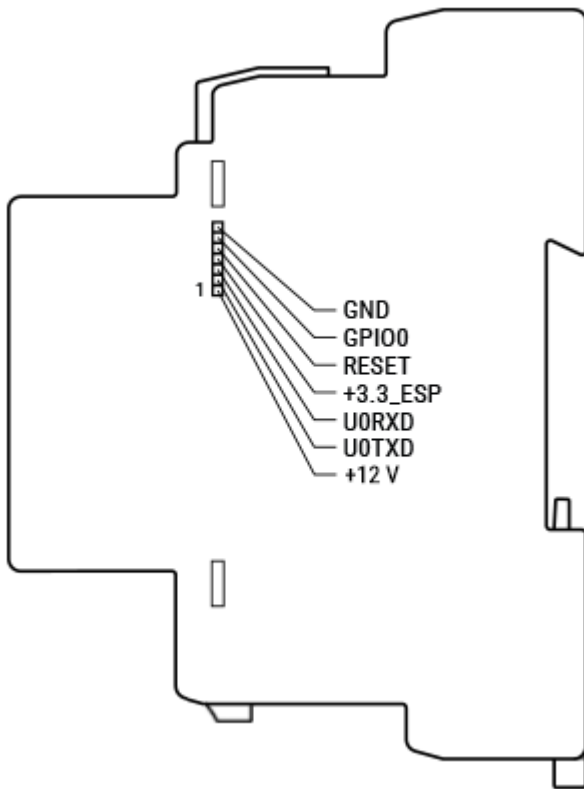

⚠CAUTION! High voltage on the add-on interface when the Device is powered!

Connectivity

- Ethernet
- Wi-Fi
- Bluetooth

Each connectivity option can be enabled or disabled by the user.

Safety features

- Overheating protection

Supported load types

- Resistive (incandescent bulbs, heating devices)
- Capacitive (LED light drivers, capacitor banks, electronic equipment, motor start capacitors)
- Inductive (transformers, fans, refrigerators, air-conditioners)

User interface

Inputs

- One tactile dome button
 - Press briefly to toggle the state of the built-in relay.
 - Press and hold for 5 sec to activate Device AP.
 - Press and hold for 10 sec to factory reset.

Outputs

- LED indication
 - Power: Red light if the power supply is connected.
 - Wi-Fi (varies):
 - Blue light if in AP mode.
 - Red light if in STA mode, and not connected to a Wi-Fi network.
 - Yellow light if in STA mode, and connected to a Wi-Fi network. Not connected to Shelly Cloud or Shelly Cloud disabled.
 - Green light if in STA mode, and connected to a Wi-Fi network and the Shelly Cloud.
 - The LED will be flashing Red/Blue if OTA update is in progress.
 - LAN: Green light if LAN is connected.
 - Out: Red light if the output relay contact is closed.
 - Count: Red light will be flashing when the Device is measuring energy according to settings with frequency dependent on the energy flowing through the measured circuit.

Specifications

Type	Value
Physical	
Size (HxWxD):	94x19x69 ±0.5 mm / 3.70x0.75x2.71 ±0.02 in
Weight:	63 ±1 g / 2.22 ±0.05 oz
Mounting:	DIN rail
Screw terminals max torque:	0.4 Nm / 4.43 lbin
Conductor cross section:	0.5 to 2.5 mm ² / 20 to 14 AWG (solid, stranded and bootlace lugs)
Conductor stripped length:	6 to 7 mm / 0.24 to 0.28 in
Shell material:	Plastic

Color:	White
Environmental	
Ambient temperature:	-20 °C to 40 °C / -5 °F to 105 °F
Humidity:	30 % to 70 % RH
Max. altitude:	2000 m / 6562 ft
Electrical	
Power supply voltage AC:	100 - 260 V, 50/60 Hz
Power supply voltage DC:	N/A
Power consumption:	< 3 W
Output circuits ratings	
Max switching voltage AC:	240 V
Max switching voltage DC:	N/A
Max switching current:	2 A
Sensors, meters	
Internal-temperature sensor:	Yes
Voltmeter (RMS):	100 - 260 V
Voltmeters accuracy:	±1 %
Ammeters (RMS via CT):	0 - 50 A
Ammeters accuracy:	±1 % (5 - 50 A), ±2 % (0 - 5 A)
Power and energy meters:	<ul style="list-style-type: none"> • Active and apparent power • Active and apparent energy • Power factor
Measurement data storage:	At least 60 days of 1 min data resolution
Data export:	<ul style="list-style-type: none"> • CSV for PQ recorded values • JSON format export through RPC
Radio	

RF band:	2400 - 2495 MHz
Max. RF power:	<20 dBm
Wi-Fi protocol:	802.11 b/g/n
Wi-Fi Range:	Up to 30 m / 100 ft indoors and 50 m / 160 ft outdoors (Depends on local conditions)
Bluetooth Protocol:	4.2
Bluetooth Range:	Up to 10 m / 33 ft indoors and 30 m / 100 ft outdoors (Depends on local conditions)
MCU	
CPU:	ESP32-D0WDQ6
Flash:	16 MB
Firmware capabilities	
Webhooks (URL actions):	20 with 5 URLs per hook
Scripting:	Yes
MQTT:	Yes
CoAP:	No

Basic wiring diagrams

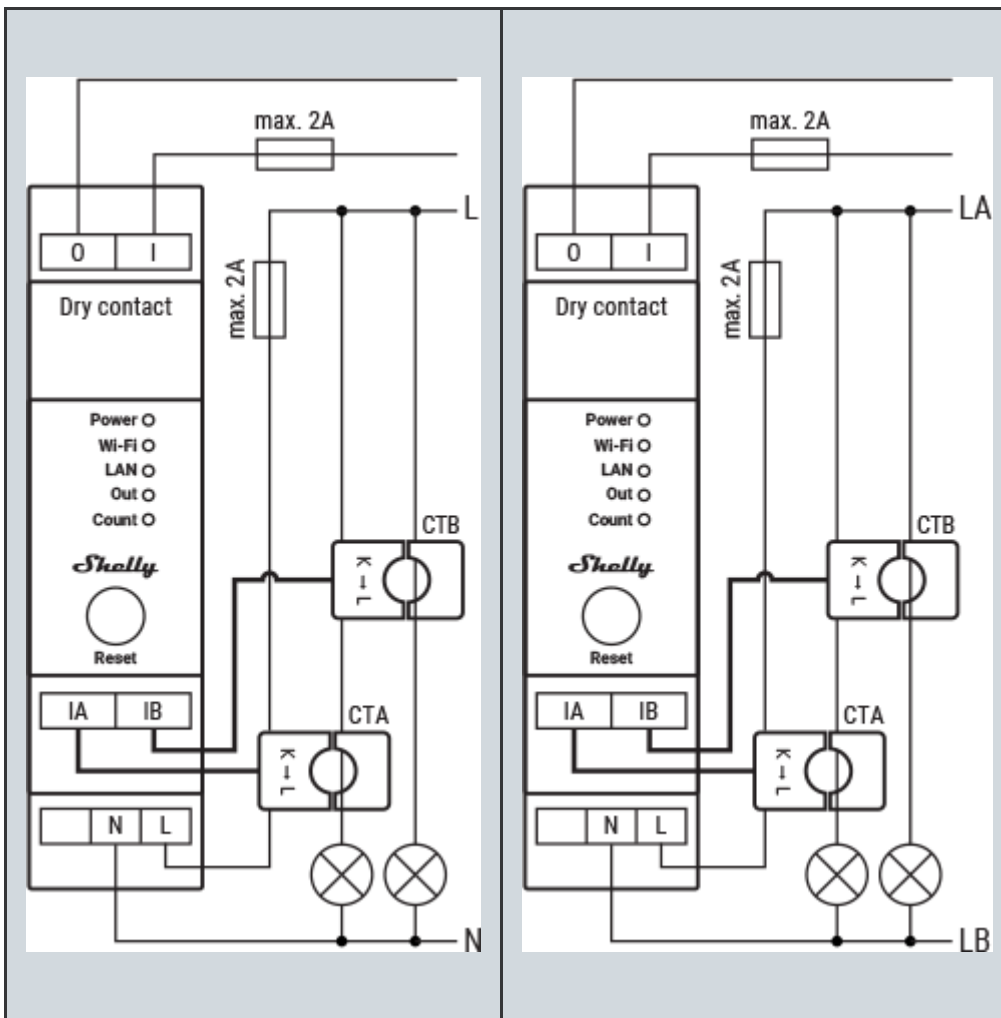

Legend

Terminals		Wires	
O	Load circuit output terminal	L	Mono-phase live (110-240 V~) wire
I	Load circuit input terminal	LA	Split-phase live A (120 V~) wire
IA	First channel current transformer input	LB	Split-phase live B (-120 V~) wire
IB	Second channel current transformer input	N	Neutral wire
L	Live (110-240 V) terminal	Current transformers	
N	Neutral terminal	CTA	First channel current transformer
		CTB	Second channel current transformer

Shelly Smart Control

- [Adding the device to the Shelly Smart Control](#)

Troubleshooting

...

Components and APIs

- [This device](#)
- [All Shelly devices and services](#)

Compliance

- [Shelly Pro EM-50 multilingual EU declaration of conformity 2025-07-25.pdf](#)
- [Shelly PRO EM - 50 UK PSTI ACT Statement of compliance.pdf](#)
- [Shelly Pro EM-50 AU NZ Certificate for Suitability.pdf](#)

Compliance archive

[Shelly Pro EM-50 multilingual EU declaration of conformity 22 2023-10-30.pdf](#)

Printed user guide

- [Shelly Pro EM-50 multilingual printed user and safety guide.pdf](#)
- [Ръководство за употреба и безопасност](#)